

# Sometimes A Small Part...

## SureFlo Aerators

by Sure Seal Incorporated

### The SureFlo Aeration System

**There's a dozen reasons to buy the SureFlo Aeration System:**

- 1.** SureFlo allows more airflow into the tank trailer than any aerator on the market today.
- 2.** SureFlo's improved and larger aerator rubber design creates more vibration than any rubber aerator available.
- 3.** Better vibration and increased airflow results in faster unloading and elimination of bridging and rat holing.
- 4.** The SureFlo Aerator has less back pressure than any aerator on the market today.
- 5.** Back flush is prevented by the use of an o-ring seal at the outer edge of the aerator.
- 6.** Easy one person installation. The aerator snaps into hopper and holds inside parts in place while you install outside housing.
- 7.** Larger opening in stainless steel abrasive wear plate than competitors wear plate allowing more airflow into tank.
- 8.** External manifold gasket keeps housing in position while preventing leaks and air flow blockage.
- 9.** Aerator components are FDA approved and built to withstand temperatures of 350° F.
- 10.** External port housings are made of engineered plastics in super tough gray and "See Through" materials in 1, 2, or 3 port designs.
- 11.** Aerators are impervious to moisture, eliminating mildew and drying time after tank cleaning.
- 12.** SureFlo Aerators are interchangeable with Solimar, Heil, Polar, and Fruehauf aerators.

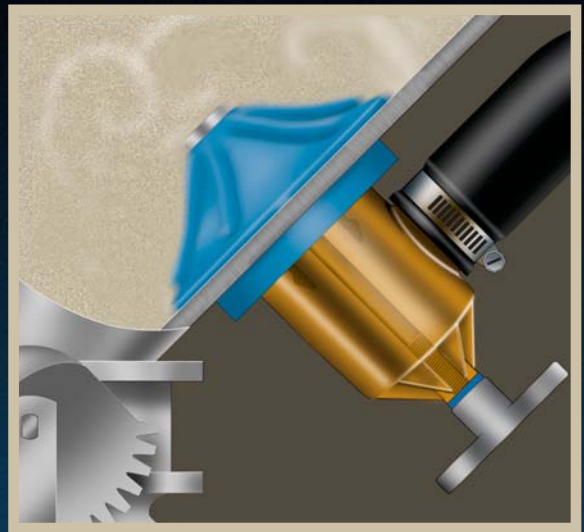

## ...makes a big difference.

### The SureFlo Aeration Advantage

SureFlo Aerators are the ultimate aerators to fluidize dry powders and bulk materials, such as flour, starch, lime, dry chemicals and plastic resins just to name a few. Comparative tests have shown increased efficiencies of 20 to 50% over competitors aeration systems.



Making a big difference to your bottom line.

For More Information on Sure Seal Products or the Name of Your Nearest Dealer Call 1-800-382-1604 • Visit us on the Web at [www.suresealinc.com](http://www.suresealinc.com)

©2005 SureSeal, Incorporated • Patent Pending

# Meet the "Air Force" of the Next Millennium!

## SureFlo Aerators

by Sure Seal Incorporated

The SureFlo Aerator is the next step in the evolution of hopper aeration. SureFlo Aerators are the ultimate aerators to fluidize dry powder bulk materials on a variety of systems from silos, rail cars, and hopper trailers to pressure differential trailers. SureFlo handles materials such as flour, starch, lime, cement, dry chemicals, and plastic resins, just to name a few.

Field tests have proven the more air you can get through the hopper wall and into the product, the faster it will unload. Comparative tests have shown increased efficiencies of 20 to 50% over competitor's aeration systems.

### A Simple Air Flow Quiz

The graphic below illustrates SureFlo's unique stem design vs. the competition. SureFlo allows up to 100% more air flow than conventional aerator stems. 1.5" hopper opening calculates to 1.767 sq. inches of possible open area through a hopper wall. Arrows illustrate air flow on vertical cross section, insets show horizontal section.

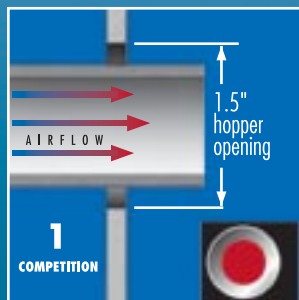

**1**  
COMPETITION  
**.672 Sq. In.**  
38% of available hopper opening

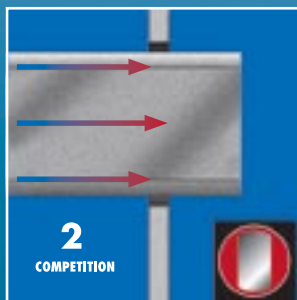

**2**  
COMPETITION  
**.690 Sq. In.**  
39% of available hopper opening

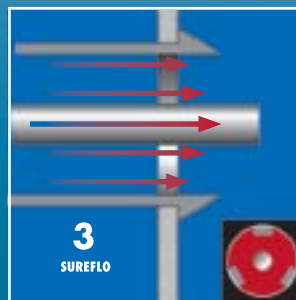

**3**  
SUREFLO  
**1.420 Sq. In.**  
80% of available hopper opening

#### You do the math.

Which opening will allow the most air flow? And therefore give you the quickest unloading times. If you choose number 3, SureFlo, go to the head of the class.

U.S. and Foreign Patents Pending

#### BENEFITS

**A.** SureFlo's stem design has over 100 percent more open area through the hopper wall than any aerator on the market today.

**B.** Our unique o-ring sealing system conforms to any hopper configuration, flat or curved, while providing a seal to prevent back flush into aeration lines.

**C.** If you've ever installed an aerator you'll appreciate SureFlo's snap retention legs. A great idea that holds the aerator in place while installing the external housing.

**D.** Stainless Steel abrasive product wear plates have 1 1/2" I.D. hole compared to 1 3/8" holes in competitor models allowing more air flow. SureSeal recommends stainless wear plates to prevent excessive wear to the hopper wall when abrasive materials are in use.

**E.** External port housings are designed in conjunction with our unique stem design to ensure perfect alignment over hopper aeration hole. Housings are available in 1, 2, or 3 ports. Material is "see through" engineered plastic and super tough grey nylon. SureFlo component parts are F.D.A. approved and withstand operating temperatures of 350° F.

**F.** Positive seal locking manifold gasket prevents leaks and keeps gaskets from sliding off port housing and blocking air flow.

**G.** SureFlo aerators are interchangeable with Solimar, Heil, Polar, and Fruehauf aerators.

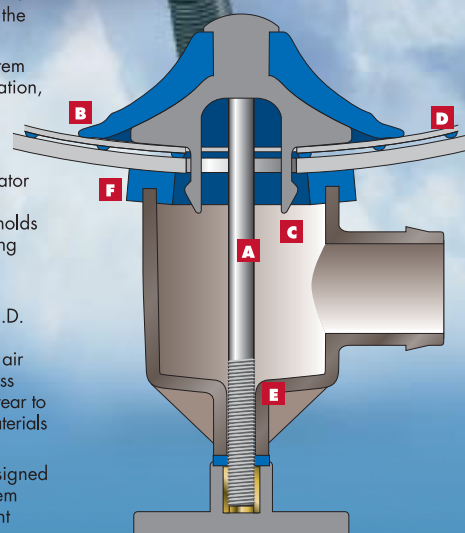

**SURE  
SEAL**  
INCORPORATED

For More Information on Sure Seal Products  
or The Name of Your Nearest Dealer Call

**1-800-382-1604**

Visit us on the web at [www.suresealinc.com](http://www.suresealinc.com)