

UNLIKE DIAPHRAGM SEALS, NON-PLUGGING GAUGE ISOLATION RING ASSURES RELIABLE PRESSURE RATINGS

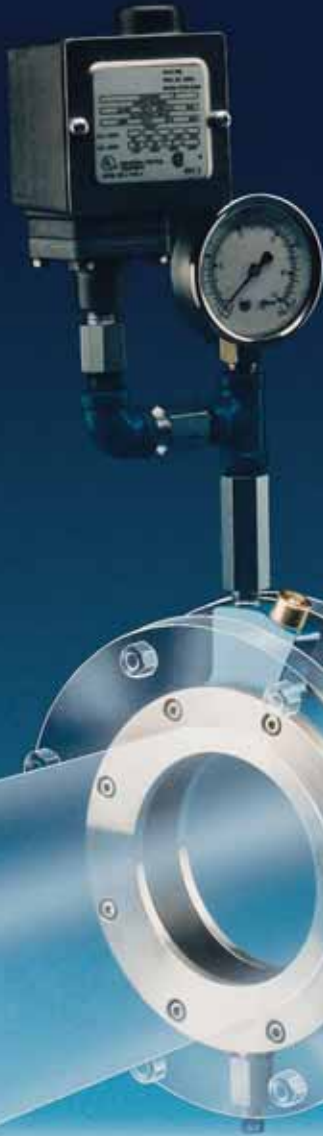

DIRECT

DIAPHRAGM
SEAL

ISO-RING®

ISO-RING®

The OPW Engineered Systems patented Gauge Isolation Ring, called ISO-Ring®, is designed to isolate gauges or pressure switches from solids in process flow and to ensure accurate pressure readings.

Clogging or fouling typically associated with diaphragm seals used in viscous fluid applications result in erroneous pressure readings. This is never a problem with the OPW ISO-Ring®.

ISO-Ring® utilizes a specially designed flush-mounted flexible inner cylinder, behind which is a clean, captive liquid. As process liquid flows through the pipe, it exerts pressure through the flexible cylinder to the captive liquid. Pressure is monitored by the gauge or the switch, which is completely isolated from the process flow.

The OPW Engineered Systems ISO-Ring is the same unit as the Ronninger-Petter unit. OPW Engineered Systems purchased the entire product line from them in 1996. Product specifications that currently read Ronninger-Petter ISO-Ring products should be changed to read OPW Engineered Systems products.

ISO-RING®

There's a common refrain reverberating throughout the industrial world these days, and its message is unmistakably clear:

Out with the old diaphragm seal. In with the OPW Engineered Systems' ISO-Ring®.

Indeed, for the steady and growing number of companies embracing and implementing this simple call-to-action, something powerfully refreshing and highly reassuring is happening as process liquid flows through their pipes:

Process flow is smooth and uninterrupted; pressure readings are consistently reliable and accurate.

Thanks to OPW Engineered Systems' advanced, patented Gauge Isolation Ring, gone are the days when solids from the process flow plug the pressure-sensing mechanism or clog the access port on the diaphragm seal.

Features and Benefits

- Gauge (or switch) is in contact only with captive liquid and never directly with the process liquid.
- Isolating the gauge (or switch) from solids in process flow results in accurate readings.
- Gauge (or switch) can be removed for calibration, repair, or replacement – without interrupting process flow.
- Unique flexible cylinder prevents plugging, which means pressure readings are reliable and accurate.
- Integral design eliminates accidental breakage.
- Adaptable to a variety of process conditions and applications.
- Will not clog (which is not true of diaphragm seals).



Ordering Information

RING OR SPOOL	BODY MATERIAL	END FLANGE MATERIAL	TYPE	FILL	Gauge	SIZE	CYLINDER MATERIALS
OR = ISO Ring® OS = ISO Spool® OB = Bolt-Thru ISO-Ring®	CS = carb. stl. SS = 316 SST	1 = carb. stl. 2 = 316 SST 3 = carb. stl. w/ Teflon® envelope 4 = 316 SST Teflon® envelope 5 = cpvc (flat faced flange) 6 = cpvc - ISO-Spool only (flat faced flange) 7 = other 8 = Fully Wetted Teflon® (Bolt-Thru ISO-Ring) carb. stl. 9 = Fully Wetted Teflon® (Bolt-Thru ISO-Ring) 316 SST	N = without IRD** I = with IRD** T = Threaded* F = Fingd/150 Lb.* G = Fingd/300 Lb.* *Spool Only ** IRD = Instrument Removal Device	00 = less fill** 11 = propylene glycol 12 = distilled water 13 = mineral oil 14 = silicone oil 15 = vegetable oil 16 = glycerine 17 = fluorolube 18 = fluorosilicone 19 = other	00 = less gauge 01 = less gauge; 1/2" conn. 02 = 0-60 psi 03 = 0-100 psi 04 = 0-200 psi 05 = 0-400 psi 06 = 0-600 psi 08 = customer supplied 09 = other	010 = 1" 015 = 1.5" 020 = 2" 025 = 2.5" 030 = 3" 040 = 4" 050 = 5" 060 = 6" 080 = 8" 100 = 10" 120 = 12" 140 = 14" 160 = 16" 180 = 18" 200 = 20"	1 = buna-n 2 = Viton® 3 = Teflon® 4 = ept* 5 = silicone** 6 = white neoprene 7 = natural rubber 8 = other *Ring Only **Spool Only

Example: ORCS 1 I 11 04 - 020 1

IMPORTANT: OPW products should be used in compliance with applicable federal, state, provincial, and local laws and regulations. Product selection should be based on physical specifications and limitations and compatibility with the environment and materials to be handled. OPW MAKES NO WARRANTY OF FITNESS FOR A PARTICULAR USE. All illustrations and specifications in this literature are based on the latest product information available at the time of publication. OPW reserves the right to make changes at any time in prices, materials, specifications and models and to discontinue models without notice or obligation.

ISO-Spool® For Small Diameter Piping

This patented product is designed to provide a large sensing area in smaller pipe diameters from 1" to 4". Offered in both NPT threaded and flanged models and available with flat or raised face.



Specifications

	ISO-Ring®	ISO-Spool®
Housing:	Carbon Steel 316 Stainless Steel	Carbon Steel
Assembly Flanges:	Carbon Steel 316 Stainless Steel CPVC	Carbon Steel 316 Stainless Steel CPVC
Inner Flexible Wall:	Buna-N Teflon® ¹ Silicone ² Viton® White Neoprene Natural Rubber	Teflon® enveloped up to 225 F (107 C) up to 350 F (177 C) up to 450 F (232 C) up to 350 F (177 C) up to 225 F (107 C) up to 225 F (107 C)
Captive Sensing Liquid:	50% Water/50% Prop. Glycol Silicone Oil (FDA Approved) Fluorosilicone Mineral Oil Distilled Water	-20 F to 200 F (-29 C to 93 C) -20 F to 450 F (-29 C to 232 C) -20 F to 450 F (-29 C to 232 C) 35 F to 225 F (1.7 C to 107 C) 35 F to 200 F (1.7 C to 93.3 C)

¹ Not Available in sizes 12" or larger ² ISO-Spool® only



Dimensions

ISO-Ring®

Pipe Size	A		B		Approx. Shipping Wt.	
	in.	mm	in.	mm	lbs	kg
2"	6- ¹ / ₆ "	(176 mm)	2"	(51 mm)	3 lbs	(1.35 kg)
3"	8- ³ / ₆ "	(208 mm)	2"	(51 mm)	6 lbs	(2.70 kg)
4"	9"	(229 mm)	1 1/2"	(38 mm)	8 lbs	(3.6 kg)
5"	10- ¹ / ₄ "	(260 mm)	1 1/2"	(38 mm)	10 lbs	(4.5 kg)
6"	11- ³ / ₆ "	(284 mm)	1 1/2"	(38 mm)	12 lbs	(5.4 kg)
8"	13- ³ / ₆ "	(340 mm)	1 1/2"	(38 mm)	16 lbs	(7.3 kg)
10"	15- ³ / ₆ "	(395 mm)	1 1/2"	(38 mm)	20 lbs	(9.1 kg)
12"	17- ³ / ₆ "	(446 mm)	1 1/2"	(44 mm)	25 lbs	(11.4 kg)
14"	19- ¹⁵ / ₆ "	(506 mm)	1 1/2"	(44 mm)	50 lbs	(22.7 kg)
16"	21- ¹⁵ / ₆ "	(557 mm)	2"	(51 mm)	60 lbs	(27.2 kg)
18"	24- ³ / ₆ "	(614 mm)	2"	(51 mm)	70 lbs	(31.8 kg)
20"	26- ¹ / ₆ "	(662 mm)	2"	(51 mm)	80 lbs	(36.3 kg)

ISO-Spool® (threaded)

Pipe Size	A		B		Approx. Shipping Wt.	
	in.	mm	in.	mm	lbs	kg
1"	3- ⁹ / ₁₆ "	(90 mm)	7 5/8"	(194 mm)	10 lbs	(4.5 kg)
1-1/2"	4- ³ / ₈ "	(111 mm)	7 7/8"	(200 mm)	12 lbs	(5.4 kg)

ISO-Spool® (flanged)

Pipe Size	Class 150		Class 300		B		Class 150		Class 300	
	in.	mm	in.	mm	in.	mm	in.	mm	in.	mm
1"	4 1/4"	(108 mm)	4 7/8"	(124 mm)	5 3/8 lbs	(136 mm)	8 lbs	(3.6 kg)	9 lbs	(4.1 kg)
1-1/2"	5"	(127 mm)	6 1/8"	(156 mm)	5 3/8 lbs	(136 mm)	10 lbs	(4.5 kg)	12 lbs	(5.4 kg)
2"	6"	(152 mm)	-	-	5 3/8 lbs	(136 mm)	15 lbs	(6.8 kg)	-	-
3"	7 1/2"	(191 mm)	-	-	5 3/8 lbs	(136 mm)	22 lbs	(10.0 kg)	-	-
4"	9"	(229 mm)	-	-	5 3/8 lbs	(136 mm)	27 lbs	(12.2 kg)	-	-

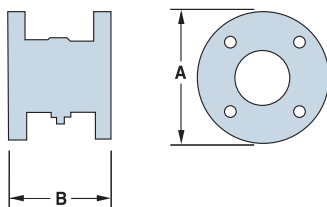
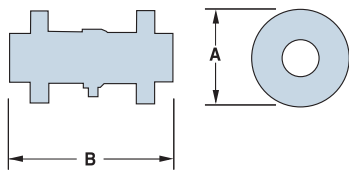
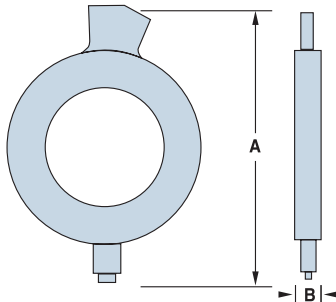

ISO-RING® SETS STANDARD FOR RELIABLE PRESSURE RATINGS

The design and engineering excellence of ISO-Ring® is embodied within a unique 360-degree flexible cylinder, behind which is a clean, captive liquid.

Here's how it works and its significance:

As process liquid flows through the pipe, it exerts pressure. This pressure is transmitted through the ISO-Ring's unique flexible cylinder to the captive liquid.

The pressure exerted by the captive liquid is monitored by the gauge's (or switch's) sensing mechanism, which is completely isolated from the flow. The gauge (or switch), thus, comes in contact only with captive liquid and never directly with the process flow.

The result: the pressure-sensing mechanism never plugs.

ISO-Ring® has no access ports; consequently, there is nowhere for solids to collect and no openings that can plug. The inner flexible cylinder is the same diameter as the inner diameter of the piping, so it's continually cleaned by the flowing liquid.

The result: pressure readings are reliable and more accurate.

In addition, ISO-Ring® pressure readings represent the circumferential average of the pipe's internal pressure distribution (not just the pressure at a single point in the line, which is all you get with a diaphragm seal).

The result: pressure readings are more consistent.

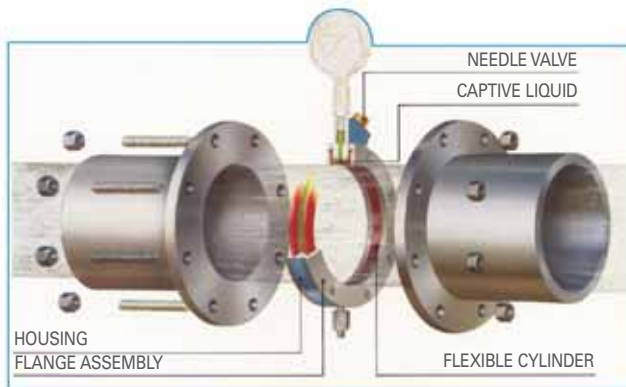

ISO-RING® PERMITS GAUGE REMOVAL FOR CALIBRATION, WITHOUT INTERRUPTING PROCESS FLOW.

A built-in needle valve is yet another unique feature of OPW Engineered Systems' ISO-Ring®.

Here's how it works and its significance:

When the needle valve is open, pressure is transmitted into the access chamber by the captive liquid. It is then monitored by a gauge or switch.

When the valve is closed, it blocks entrance to the access chamber.

The result: users have the freedom and flexibility to remove the pressure instrument for calibration, repair or replacement – without shutting down the process flow. The system remains on stream and no captive liquid is lost.

There are other important design advantages of ISO-Ring®, specifically:

- The needle valve is an integral part of the unit's housing, which means accidental breakage during transit, installation, or while in service, is virtually impossible.
- The needle valve, when adjusted to the "nearly closed" position, also acts as a snubber, which dampens pressure spikes that may occur, for example, from system upsets. This helps protect pressure instruments from damage.

- The ISO-Ring® is dramatically lighter in weight (vs. units from other manufacturers) and, therefore, substantially easier and more cost efficient to ship and install. The ISO-Ring® 8-inch unit, for example, weighs 16 pounds, whereas similar-sized units from other manufacturers weigh up to 58 pounds. As the unit size increases, so too does the comparative weight differential.
- The ISO-Ring® also is adaptable to a variety of process conditions and applications, including for the protection of delicate, expensive instrumentation (when used with a simple pressure gauge). Also available for piping diameters from 2" to 20" ISO-Ring® can be used at any pressure within the limitations of ASME Classes 150 and 300, and in most vacuum applications.

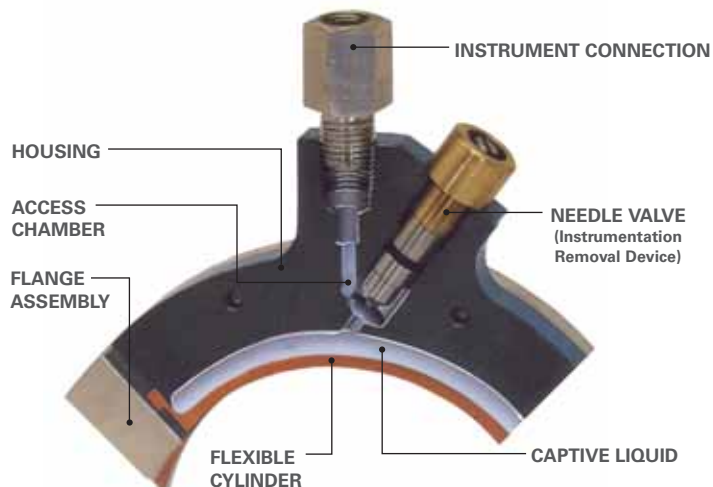

IMPORTANT: OPW products should be used in compliance with applicable federal, state, provincial, and local laws and regulations. Product selection should be based on physical specifications and limitations and compatibility with the environment and materials to be handled. OPW MAKES NO WARRANTY OF FITNESS FOR A PARTICULAR USE. All illustrations and specifications in this literature are based on the latest product information available at the time of publication. OPW reserves the right to make changes at any time in prices, materials, specifications and models and to discontinue models without notice or obligation.